

Assignment 3: Reflection

At this point, you need to document and reflect on work process and outcomes to date. Your job is to demonstrate how your work addresses accreditation guidelines. For each of the following points, consider how have you addressed the criteria. What did you learn? How will this shape your further studies?

Our class will be using the <http://eportfolio.uoregon.edu> to collect, reflect on and display studio work. E-portfolio makes it simple to build and maintain a graphic website. You can upload images and link in files, creating homepages using a visual editor. You will be able to link in current and future classwork: your account should remain live even after graduation. The work goes into a content management system (CMS) database, so faculty can filter work by title, keyword, date, etc. to create specialized galleries.

Each Architecture student must maintain a digital portfolio that records all design studio major projects counting towards the professional degree. The digital portfolio will help you

- hone visual communication skills
- reflect on lessons learned and
- connect with potential employers.

To get started, we need you to create a home page, a studio folder, create pages in that folder

Studio Project Description
Individual Site Concept
Group Site Design
Reflections

1. DRAFT THE REFLECTION TEXT

Please write 100 to 200 words about each of the following topics. During class, we can work on posting them on the E-portfolio system with digital images. You will have opportunity to revise and reflect on these pages throughout the term. The reflections can remain private to you and your instructor or you can choose to publish them.

A. Design concept

What was the main ideal or metaphor? What were your design objectives?

B. Site Design (NAAB#17 Site Conditions)

Ability to respond to natural and built site characteristics in the development of a program and the design of a project

Your challenge is to cherry-pick top ideas from the mid-review and integrate them into a coherent scheme. Without worrying about ownership, describe the approach to landscape, circulation, program clusters and massing that fit the situation best. Describe an emerging metaphor that seems ripe with promise.

C. Program (NAAB #12 Human Behavior)

Understanding of the theories and methods of inquiry that seek to clarify the relationship between human behavior and the physical environment

How does this environment suit Wellsprings & the Mennonite Peace Church? Explain ideas for social and economical sustainability.

D. Spatial Composition (NAAB#5 Formal Ordering Systems)

Understanding of the fundamentals of visual perception and the principles and systems of order that inform two- and three-dimensional design, architectural composition, and urban design

Describe and show how the scheme's massing & circulation have a coherent organization.

E. Sustainable Design (NAAB #15)

Understanding of the principles of sustainability in making architecture and urban design decisions that conserve natural and built resources, including culturally important buildings and sites, and in the creation of healthful buildings and communities

Explain how the building works ecologically in terms of sun and wind, Identify green topics for further exploration.

F. Collaborative Skills (NAAB#7)

Ability to recognize the varied talent found in interdisciplinary design project teams in professional practice and work in collaboration with other students as members of a design team

F1. Productively blending creative ideas is a big challenge common to every building endeavor. How did you develop your design together? What worked well this time and what was difficult? What techniques helped you break through impasses? >> Discuss your teamwork process

F2. You have three choices for developing your Building Design for Nov. 3: stay in your current group, form a new group with up to 4 students or work on your own. Partners can provide support, complementary skills, and fuller design development; they require patience and negotiation. >> Explain your choice. You may switch your choice after the Nov. 3 review.

G. Graphic Skills (NAAB#3)

Ability to use appropriate representational media, including freehand drawing and computer technology, to convey essential formal elements at each stage of the programming and design process

How did the crafting of materials or digital media shape the project? What methods could expand your toolkit?

2. FORMAT DIGITAL COMPONENTS FOR E-PORTFOLIO

Scan drawings, photograph handmade pieces with a digital camera.

For tutorial videos on improving scanned drawings and compiling multipage PDF's, see

http://archgraphics.blogspot.com/2007_09_01_archive.html

For each assignment, save at least one **.JPG horizontal format** glamour image at **800 pixels wide x 600 pixels** high. Save **Adobe Acrobat .PDF** file for complex & multipage layouts.

Follow naming conventions for images to appear in our class gallery.

484f08_login_as1.jpg or *484f08_login_as1.pdf* where

"login" is your UOREGON.EDU user name

"as1" shows the assignment number

".jpg" or ".pdf" is the file type

3. LOGIN AND UPLOAD IMAGE FILES

Use the login and password that was emailed to you. "jsmith" NOT jsmith@uoregon.edu

View tab > Add to folder > Image

NOTE: For PDF files to display correctly, load it as a FILE:

View tab > Add to folder > File

4. CREATE A HOME PAGE

View tab > Add to folder > Page

Choose the Edit tab to begin creating a self-descriptive home page. Place a preview or mini version of your glamour image. This image can be linked to a page about the studio. All images and files must be uploaded BEFORE they are linked in. When you choose to place the image, you must select a display size (Large, Preview, Mini).

5. CREATE A STUDIO FOLDER

View tab > Add to folder > Folder

Name the folder arch 484 or arch 584, Click to open it

6. CREATE STUDIO PAGES IN THE STUDIO FOLDER

View tab > *Add to folder* > *Page*

A. STUDIO PROJECT DESCRIPTION

Label: Name, program, instructor, Course number & name, Term, Project name
Jane Smith, B.Arch. candidate, Prof. Nancy Cheng, Arch 4/584 Architectural Design, Fall '08, Wellsprings School

Problem Statement: Summarize the assignment in a sentence or two

Design a school and church building that cultivates community, stimulates love of learning and nourishes the soul. Demonstrate the ability to orchestrate architectural and natural spaces, integrate sustainable design principles.

B. PROCESS: Individual Site Concept

conceptual site model, 3 section & 3 plan diagrams, paragraph about the concept

C. PROCESS: Group design summary (link to shared pages)

3 massing alternatives
sustainability images & bullet points,
5 diagrams
site model, site plan, site sections, perspective sketches

C. REFLECTIONS on NAAB Student Performance Criteria

These are like journal entries; you will add onto these as you go along, you can keep these private (aka Public Draft since I and other administrators can see the page)

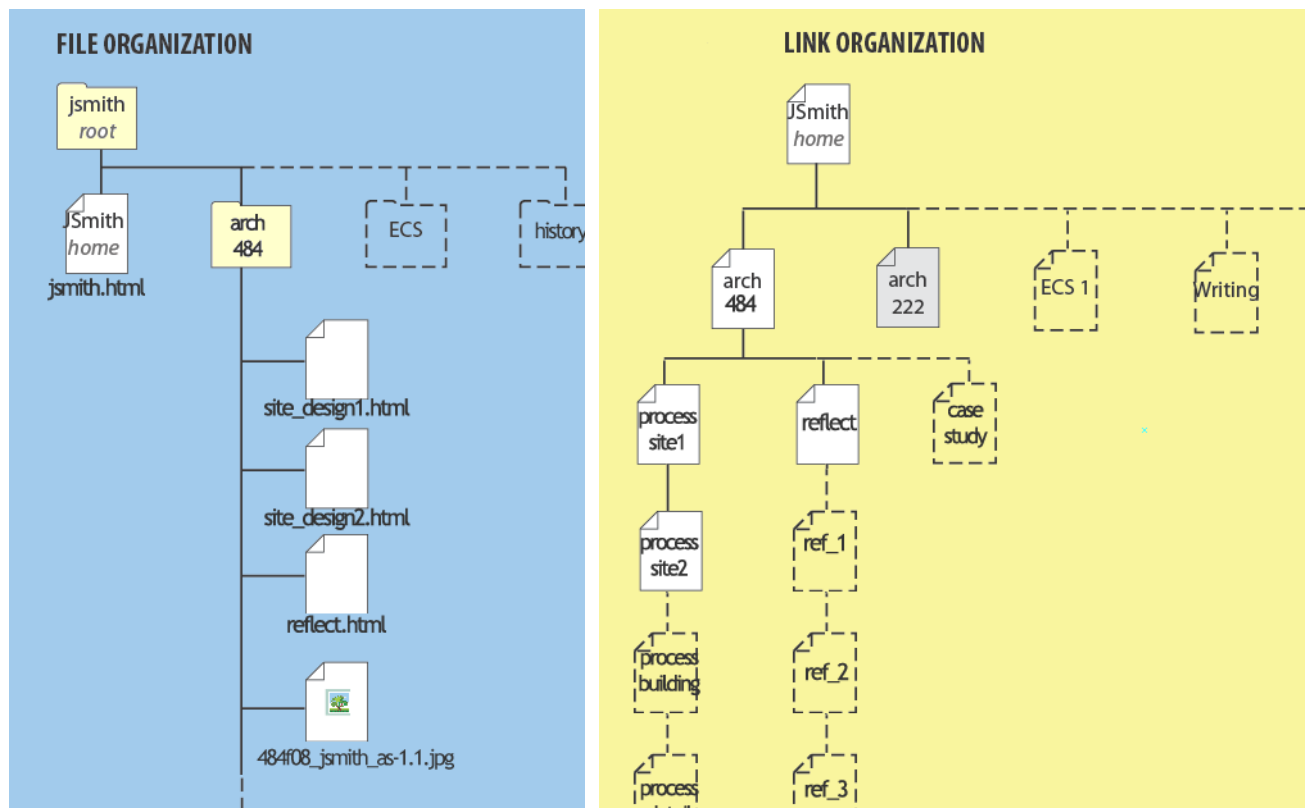

The first two videos on this page introduce the Eportfolio's underlying Plone system and show how to edit.

<http://plone.org/about/movies/>